

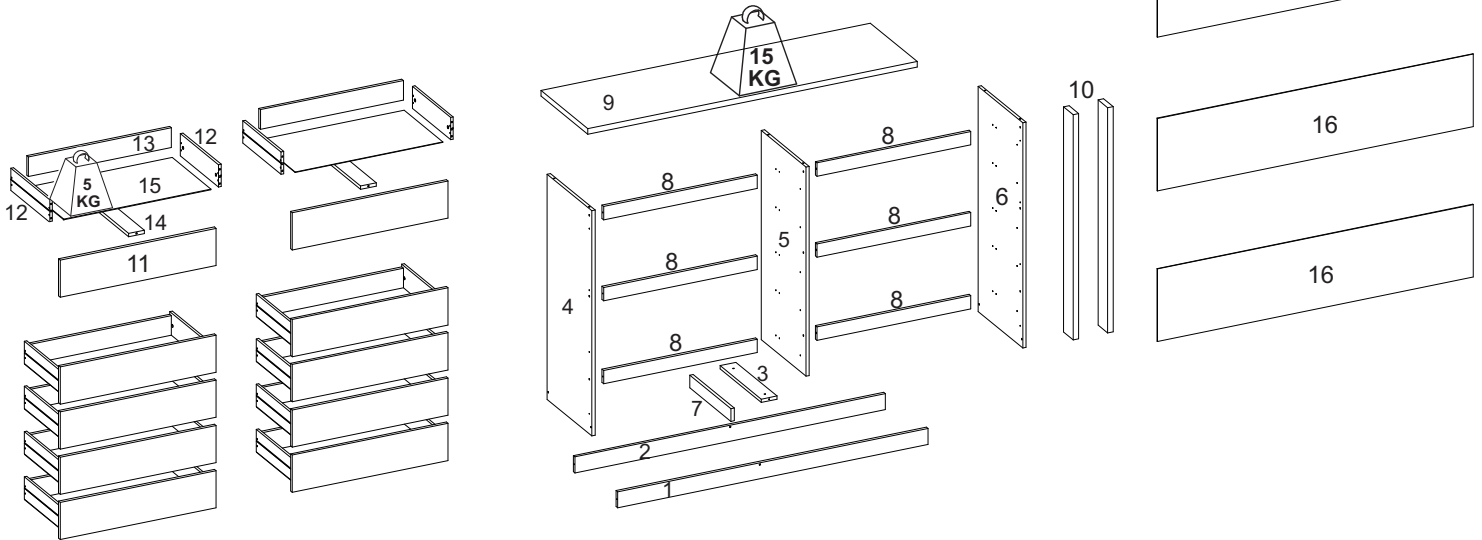

## 189 - CÔMODA DUETTO



### LISTA DE PEÇAS / Pieces List / Lista de Piezas

SEQ.	REF.	DESCRIÇÃO	DESCRIPTION	DESCRIPCIÓN	MAT.PRIMA	COMP.	LARG.	ESP.	QTD.
1	331754	Rodapé frontal	Front footer	Pie de página frontal	MDP	1423	72	15	1
2	331755	Rodapé traseiro	Back footer	Pie de página posterior	MDP	1423	72	15	1
3	331756	Trava divisória	Partition lock	Bloqueo de partición	MDP	377	72	15	1
4	331757	Lateral esquerda	Left side	Lado izquierdo	MDP	1012	410	15	1
5	331758	Divisória	Divider	Divisor	MDP	940	410	15	1
6	331759	Lateral direita	Right side	Lado derecho	MDP	1012	410	15	1
7	331760	Trava rodapé	Footer lock	Bloqueo de pie de página	MDP	377	57	15	1
8	331761	Vista gaveta	Drawer view	Vista del cajón	MDP	704	60	15	6
9	331762	Tampo	Cover	Cubrir	MDP	1510	430	25	1
10	331763	Vista lateral	Side view	Vista lateral	MDP	1012	88	25	2
11	331764	Frente de gaveta	Drawer front	Frente del cajón	MDP	714	167	15	10
12	331765	Lateral de gaveta	Drawer side	Lado del cajón	MDP	350	100	12	20
13	331766	Contra fundo	Against background	Contra el fondo	MDP	655	88	15	10
14	331767	Apoio de gaveta	Drawer support	Soporte de cajón	MDP	350	72	15	10
15	331768	Fundo da gaveta	Drawer bottom	Fondo del cajón	HDF	677	355	3	10
16	331769	Fundo	Bottom	Abajo	HDF	1447	326	3	3

**INSTRUÇÃO MONTAGEM PRODUTO**  
 Instructions to Assembly / Instrucciones de montaje

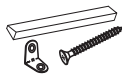

Separe as peças e acessórios de maneira organizada  
 Separate parts and accessories in way organized  
 Separe las piezas y accesorios de manera organizada

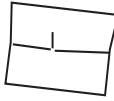

Forrar o chão com o papelão das embalagens.  
 Cover the floor with the cardboard  
 Cubra el suelo con la embalaje de cartón



É necessário 1 pessoa para montar o produto  
 01 people are required to assemble the product  
 Se requieren 01 persona para ensamblar el producto

O produto deve ser a montado por um profissional qualificado  
 The product must be assembly by a professional  
 El producto debe ser ensamblado por un profesional calificado

Ferramentas necessárias  
 (não fornecidas)

Not include tools / No herramientas



**CUIDADO PARA CONSERVAÇÃO E LIMPEZA DO MÓVEL**  
 Care to conservation and clean / Cuidados de limpieza

Peso máximo de carga informado refere-se a objetos distribuído de maneira uniforme sobre toda área de contato da peça



The maximum load weight informed refers to objects distributed evenly over the entire contact area of the part  
 Conjunto de carga máxima de peso se refiere a objetos distribuidos uniformemente sobre toda el área de contacto de la pieza de trabajo.



Não molhar o móvel e não expor em lugar úmido  
 Do not wet the mobile and do not expose in a wet place  
 No moje el producto y no exponer en un lugar húmedo



Não expor o móvel próximo de fontes de calor.  
 Do not expose the mobile near heat sources  
 no exponga cercano de fuentes de calor



Não usar produtos abrasivos.  
 Do not use abrasive products.  
 No utilice productos abrasivos.



Limpe com flanela limpa e seca.  
 Clean with dry cloth  
 Limpieza con un paño limpio y seco

**LISTA DE ACESSÓRIOS E FERRAGENS / ACCESSORIES AND HARDWARE / ACCESORIOS Y HARDWARE**

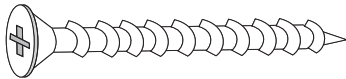

A- 700137-Parafuso 4,5x45 (14x)  
 screw / tornillo



B- 700124-Parafuso 3,5x25 (56x)  
 screw / tornillo



C- 700121-Parafuso 3,5x12 (308x)  
 screw / tornillo



D- 700146-Parafuso minifix (20x)  
 Minifix screw / Tornillo minifix



E- 700148-Tambor Minifix (20x)  
 Minifix Drum / Tambor minifix



F- 700542-Cavilha 6x30 (68x)  
 peg / cerrojo



G- 700157-Prego (166x)  
 nail / clavo



H- 700692-Perfil H (02x)  
 Frame / Perfil



I- 700538-Cantoneira (10x)  
 corner / esquina



J - 700539-Cantoneira (12x)  
 corner / esquina



K -700490 - Kit com 6 pes (01x)  
 wardrobe feet / alquiler de piso



L - 700113-Corrediça (10x)  
 runners / corredera



M- 700419-Tapa furo minifix (42x)  
 cover / tapa



N- 700516-Sache cola 20g (02x)  
 Glue / Goma

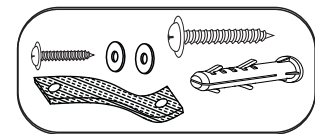

O- 703012 - Kit anti tonbamento (01x)  
 Anti-tip kit / Kit antivuelco

01° PASSO - Fixar os acessórios nas peças 4,5 e 6

01° STEP - Fix accessory to parts 4,5 and 6

01° PASO - Fijar el accesorio las partes 4,5 y 6

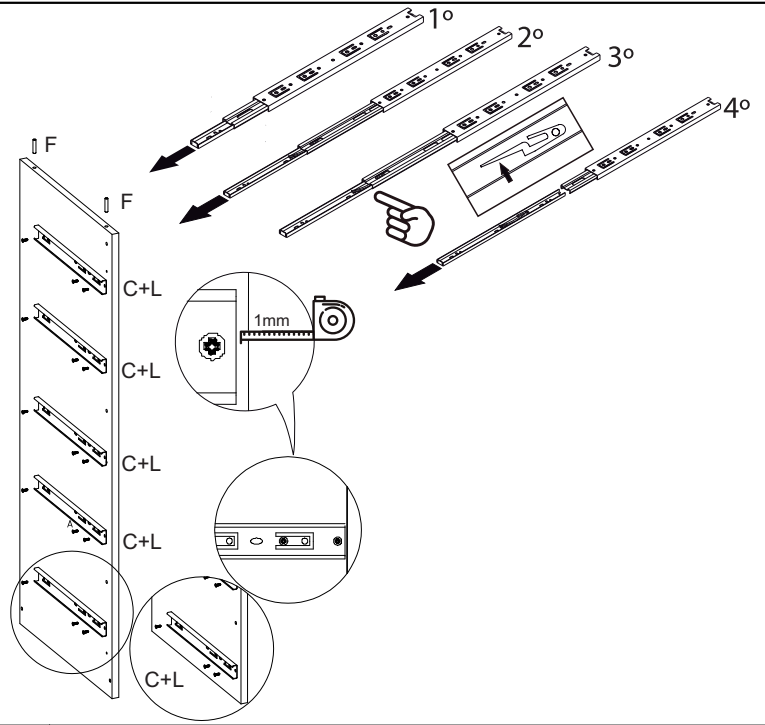
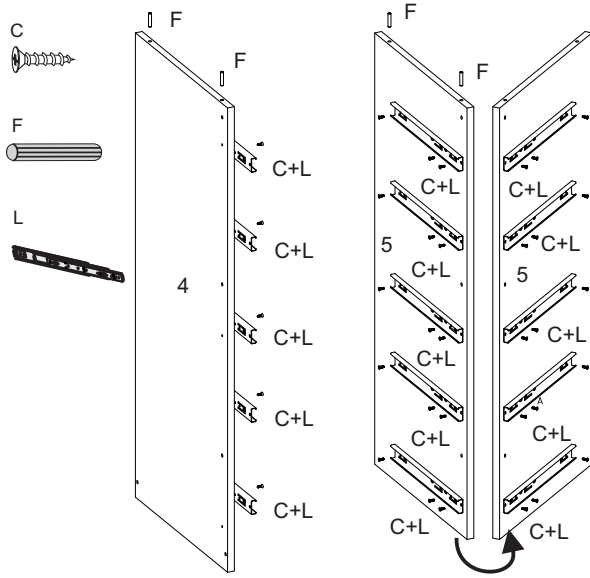

02° PASSO - Fixar peça 3 nas peças 1 e 2

02° STEP - Fix part 3 to parts 1 and 2

02° PASO - Fijar la pieza 3 a las piezas 1 y 2.

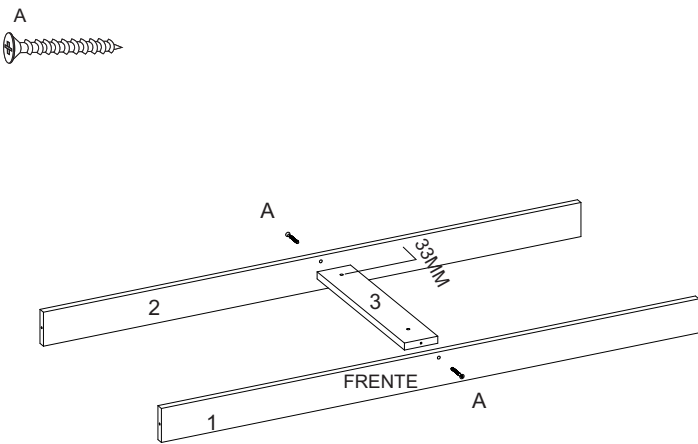

03° PASSO - Fixar as peças 4,5 e 6 nas peças 1,2 e 3

03° STEP - Fijar parts 4,5 and 6 to parts 1,2 and 3

03° PASO - Fijar las piezas 4,5 y 6 a las piezas 1,2 y 3.

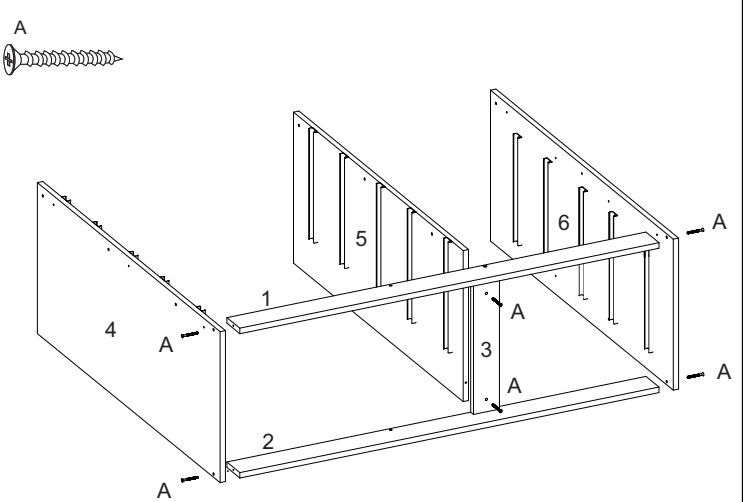

04° PASSO - Fixar a peça 7 nas peça 1 e 2

04° STEP - Fix parts 7 to parts 1 and 2

04° PASO - Fijar la pieza 7 a las partes 1 y 2

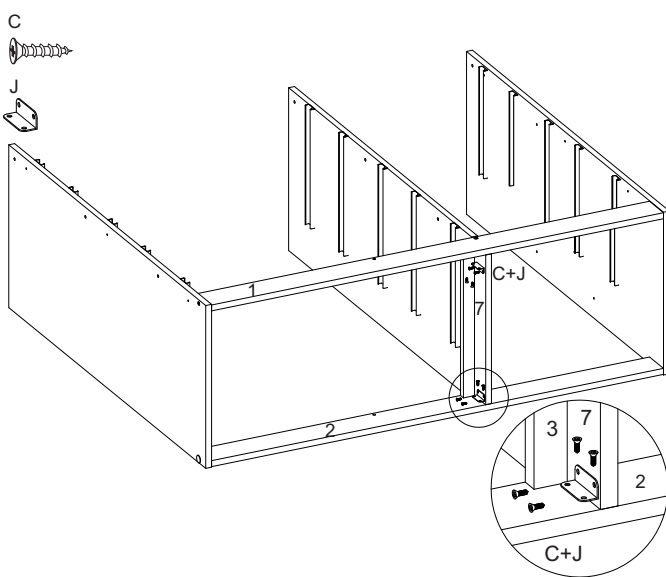

05° PASSO - Fixar o Kit pé

05° STEP - Fix the Foot Kit

05° PASO - Fijar el kit de pies

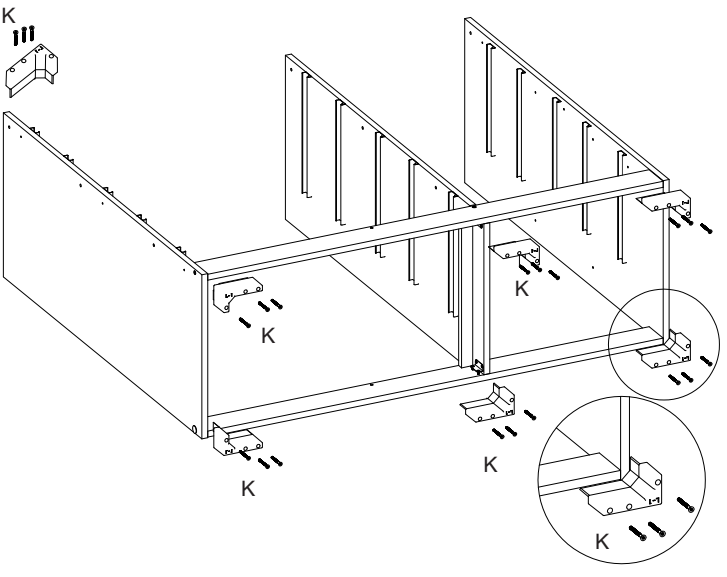

06° PASSO - Fixar peças 8 nas peça 4,5 e 6

06° STEP - Fix parts 8 to parts 4,5 and 6

06° PASO - Fijar las piezas 8 a las piezas 4,5 y 6.

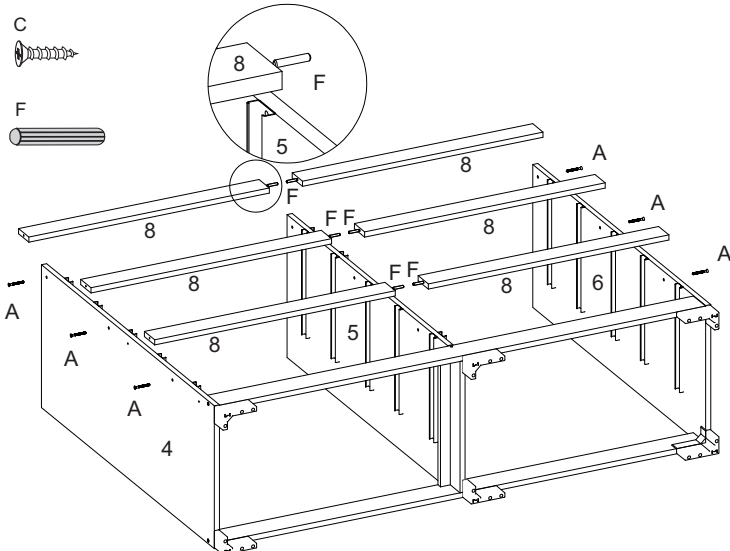

07° PASSO - Fixar acessórios (C+J) nas peças 5 e 8

07° STEP - Fix accessories (C+J) to parts 5 and 8

07° PASO - Fijar los accesorios (C+J) a las piezas 5 y 8

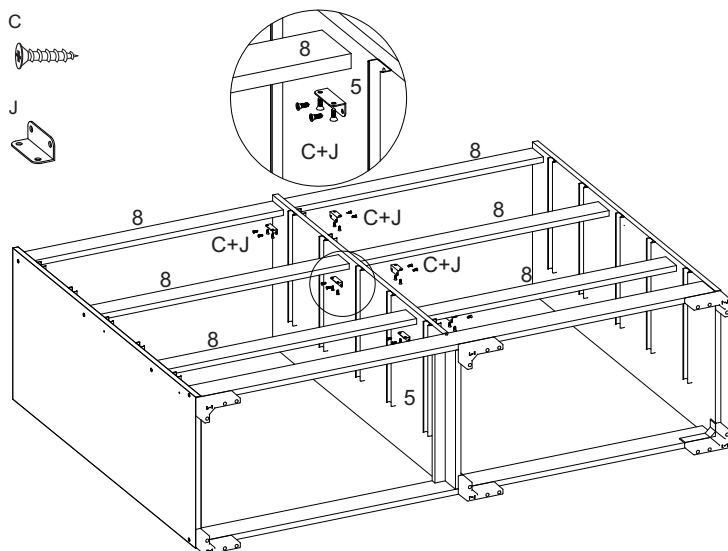

08° PASSO - Fixar peça 9 nas peças 4,5 e 6

08° STEP - Fix part 9 to parts 4,5 and 6

08° PASO - Fijar la pieza 9 a las piezas 4,5 y 6.

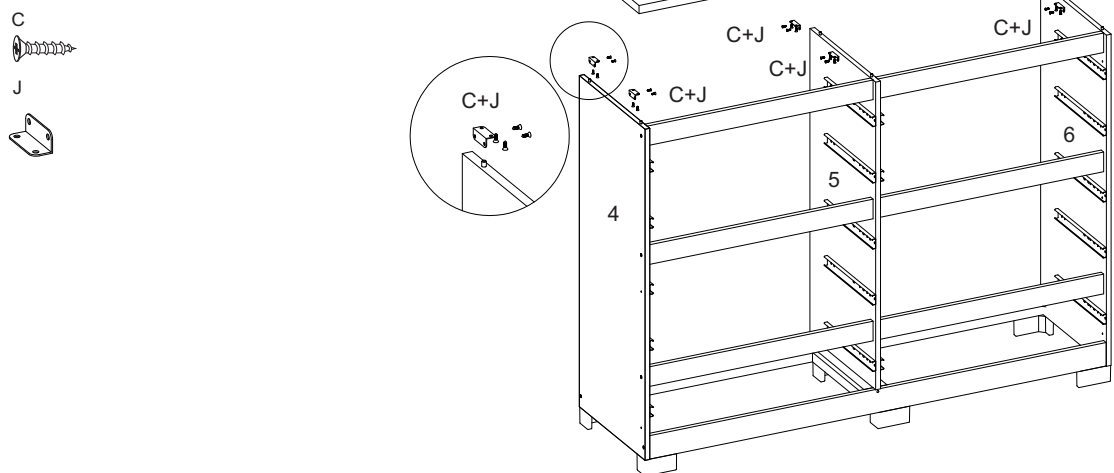

09° PASSO - Fixar peças 10 nas peças 4 e 6

09° STEP - Fix parts 10 to parts 4 and 6

09° PASO - Fijar las piezas 10 a las piezas 4 y 6.

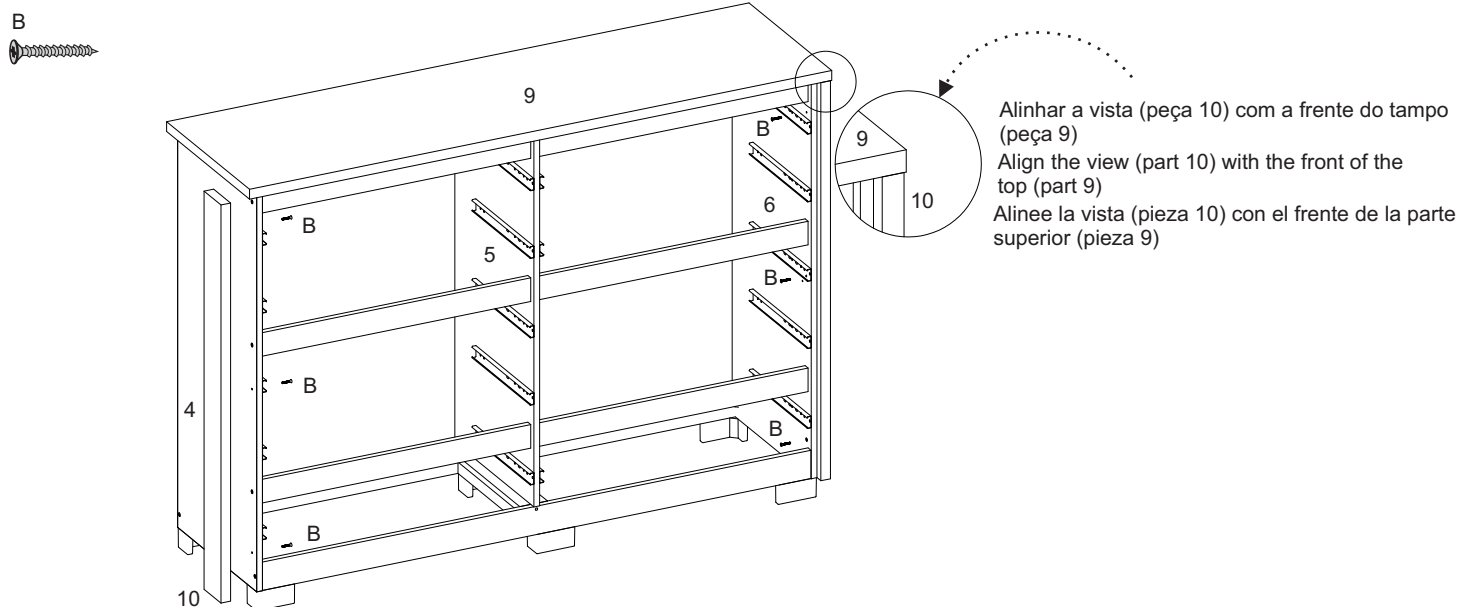

10º PASSO - Fixar peças 16 na parte de trás do produto

10º STEP - Fix parts 16 to part the back of the product

10º PASO - Fijar piezas 16 en la parte posterior del producto.

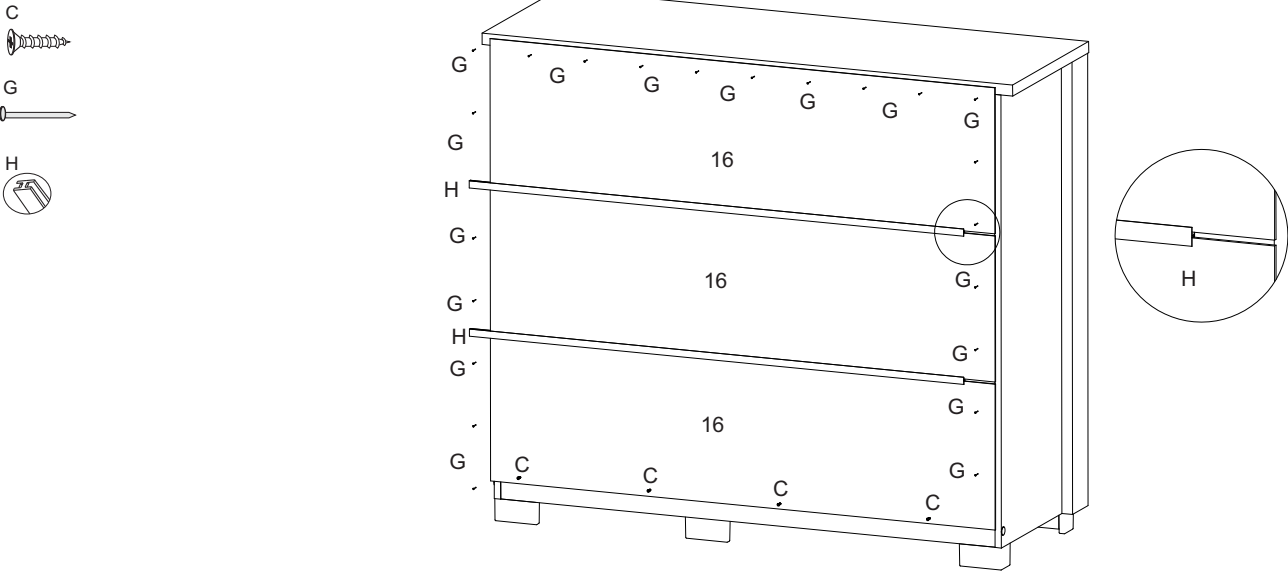

11º PASSO - Fixar peças 12 nas peças 11 e 13

11º STEP - Fix parts 12 to parts 11 and 13

11º PASO - Fijar las piezas 12 a las piezas 11 y 13.

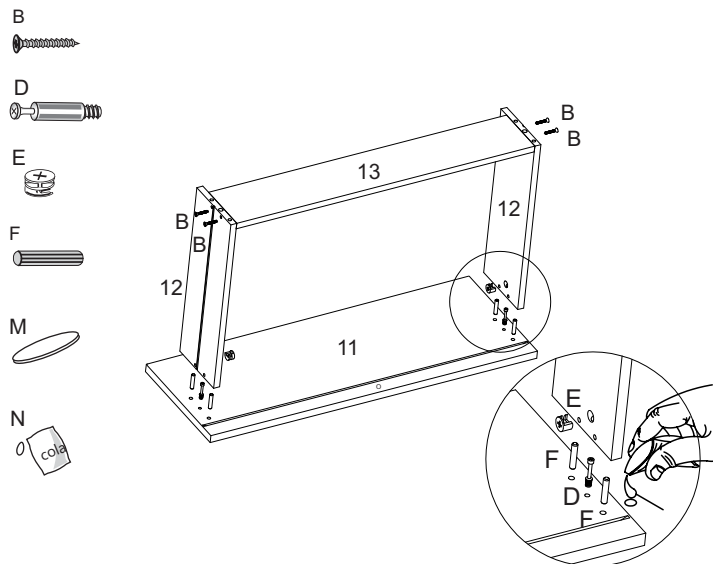

12º PASSO - Fixar peças 15 nas peças 12 e 13

12º STEP - Fix parts 15 to parts 12 and 13

12º PASO - Fijar las piezas 15 a las piezas 12 y 13.

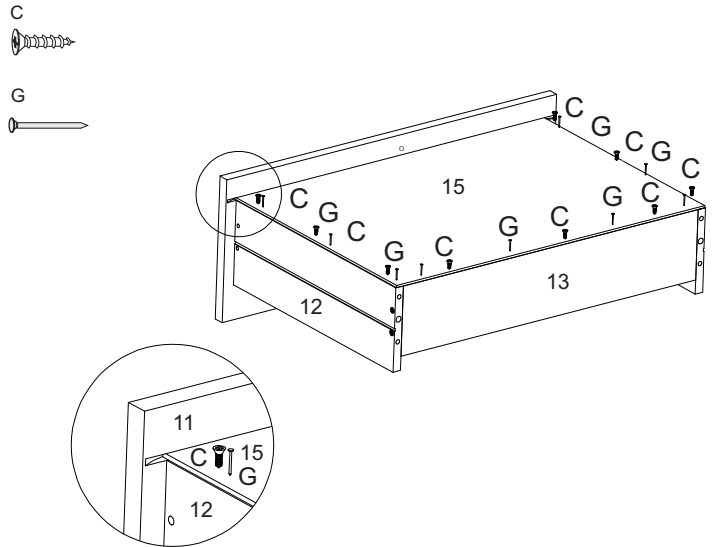

13º PASSO - Fixar peça 14 nas peças 11 e 13

13º STEP - Fix part 14 to parts 11 and 13

13º PASO - Fijar la parte 14 a las partes 11 y 13

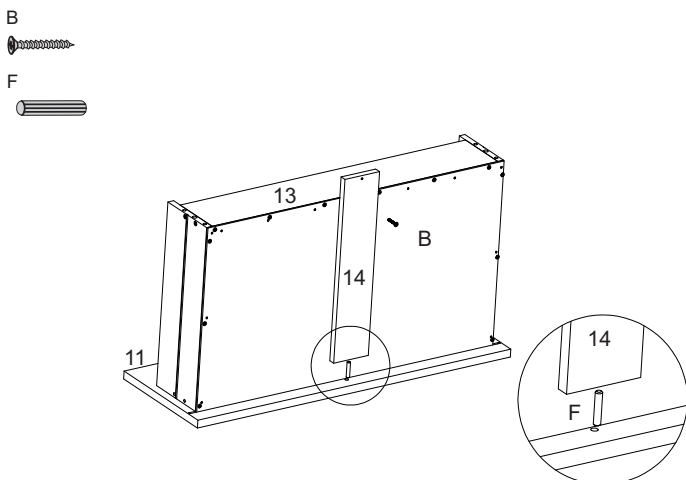

14º PASSO - Fixar acessório (C+L) nas peças 12

14º STEP - Fix accessory (C+L) to parts 12

14º PASO - Fijar el accesorio (C+L) a las piezas 12

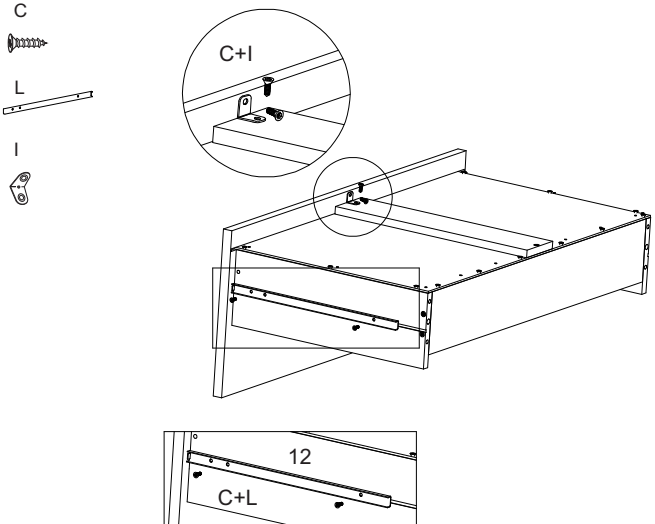

15° PASSO - Encaixar as gavetas no produto

15° STEP - Fitting the drawers to the product

15° PASO - Montaje de los cajones al producto.

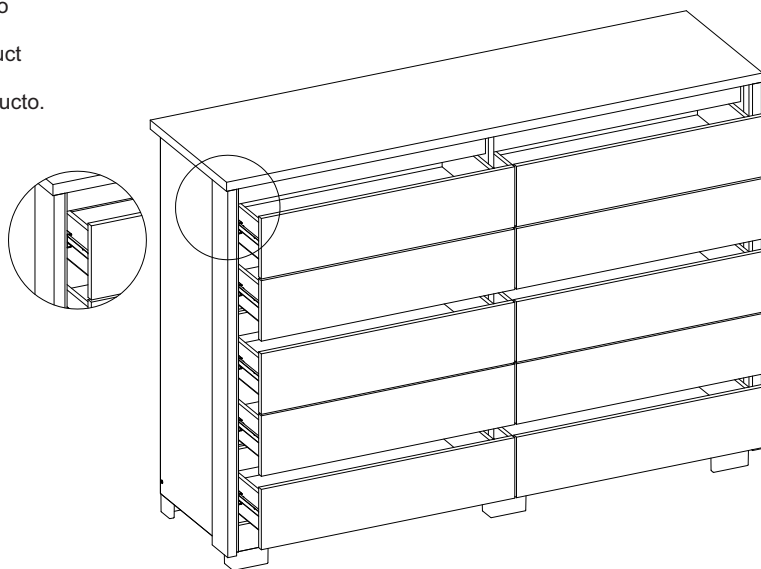

O produto contém um kit anti tombamento que deve ser fixado na parede e na parte traseira do produto

The product contains an anti-tip kit that must be fixed to the wall and back of the product

El producto contiene un kit antivuelco que debe fijarse a la pared y a la parte posterior del producto

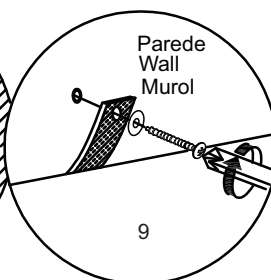
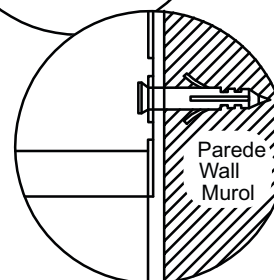
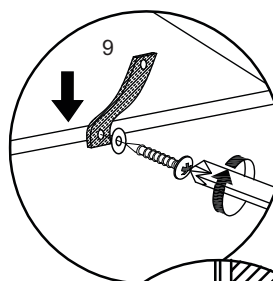
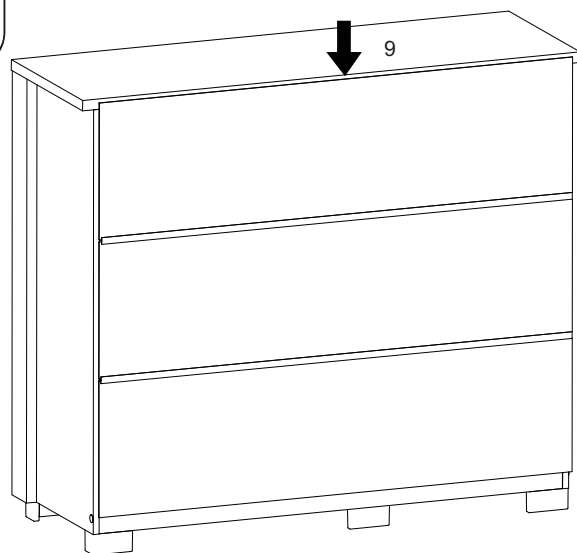
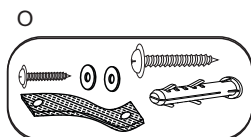

Aspecto final do produto

Final product aspect

Aspecto final del producto

